

POLYCAST®

400 Series Drain System for Residential and Athletic Facility Applications



The POLYCAST® 400 Series Drain System is a complete surface drainage system that provides efficient drainage while maximizing life cycle costs because of its exceptional durability.

- The precast polymer trench is three times stronger than ordinary concrete and is resistant to most salts, acids and alkalines.
- The strong polymer concrete construction and smooth interior surface walls make the system virtually maintenance-free.
- The ease of installation and the modular design of the drain system also reduces construction costs, making it an economical solution for track and field applications.

Inexpensive and long-lasting, POLYCAST® 400 Series is the perfect drainage system for tennis courts, swimming pools, walkways, patios, garage doors and many other residential and athletic facility applications.

Benefits and Features:

- **Strong**
- **Lightweight**
- **Easy to Install**
- **Durable**
- **Maintenance-Free**
- **Chemical Resistant**
- **Cost Effective**



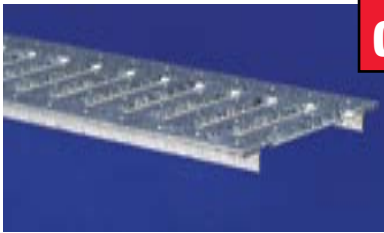

Grating

The POLYCAST® 400 Series is a complete surface drainage system consisting of a precast polymer concrete trench and a tight-fitting galvanized steel grate. The steel grate is bicycle and wheelchair resistant and will support automobile traffic. The precast trench and grate are available in 2' and 4' lengths.

(2' Slotted Grating - Part No. DG0441 / 4' Slotted Grating - Part No. DG0442)

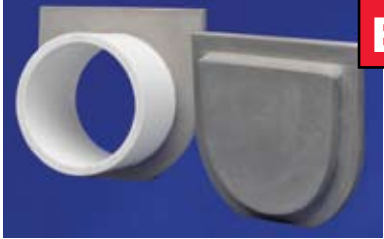

End Caps

Drain end caps are available for 3" PVC pipe. Solid end caps are also available to seal off the ends of the channels.

(3" Drain End Cap - Part No. DP0405D / Closed End Cap - Part No. DP0405C)



Installation Chair

The POLYCAST® Installation Chair is the most efficient and economical means of setting a precast trench system. The installation chair supports the ends of the channels, aligns and locks the joint rigidly together and prevents the channels from floating. Adjusting channel elevation is easy with the POLYCAST® Installation Chair.

(Installation Chair - Part No. DA0634)



Hold-Down Device

One hold-down device is recommended per every 2' of grating.

(Hold-Down Device - Part No. DA0642)



Technical Information

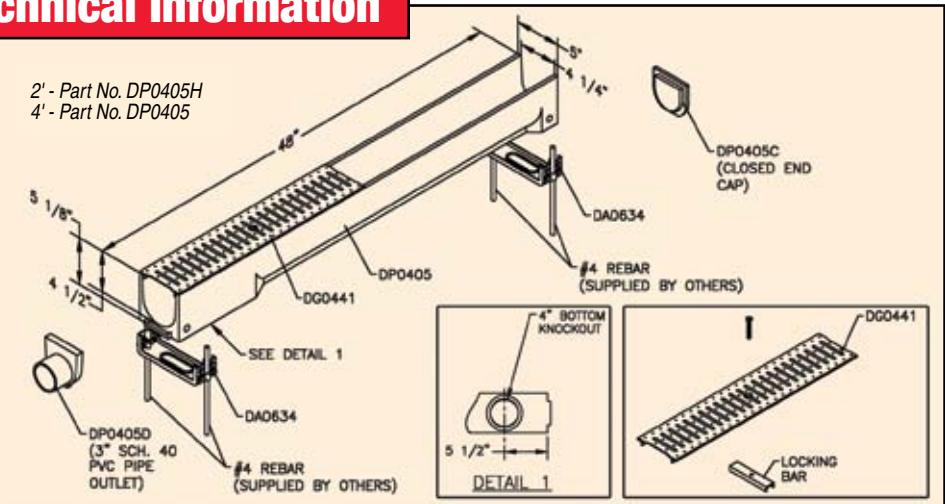

© POLYCAST®
3621 Industrial Park Drive
Lenoir City, TN 37771
Phone: 800-346-3061 or 865-986-9726
Fax: 865-986-0585
Web: <http://www.polycastdrain.com>
e-mail: hpsliterature@hps.hubbell.com